

# DKG-527 AUTOMATIC MAINS FAILURE UNIT WITH J1939 INTERFACE

## DESCRIPTION

The DKG-527 is a comprehensive AMF unit for a single generating set operating in standby mode.

The unit can connect to ECU controlled electronic engines through its standard J1939 CANBUS port providing engine control, protection and instrumentation without extra senders. The ECU alarms are displayed with SPN-FMI codes.

In AUTOMATIC position, DKG-527 monitors mains phase voltages and controls the automatic starting, stopping and load transfer of the generating set in case of a mains failure and once the generator is running, it monitors internal protections and external fault inputs. If a fault condition occurs, the unit shuts down the engine automatically and indicates the failure source with the corresponding red led lamp.

The operation of the unit is controlled with front panel pushbuttons. The LOAD TEST, TEST, AUTO and OFF pushbuttons select the operating mode. Other buttons select the display parameter scroll, alarm mute and lamp test functions.

The DKG-527 provides a comprehensive set of digitally adjustable timers, threshold levels, input and output configurations, operating sequences and engine types. The unauthorized access to program parameters is prevented by the program lock input. All programs may be modified via front panel pushbuttons, and do not require an external unit.

The fault conditions are considered in 2 categories as Warnings and Alarms. Measured values have separate programmable limits for warning and alarm conditions. The unit is able to initiate modem calls and sending SMS messages in fault conditions.

The service request indicator lamp turns on at the expiration of either engine hours or time limits.

It is possible to monitor and control the operation of the system locally or remotely with the WINDOWS based RAINBOW program.

The unit supports MODBUS protocol enabling communication with PLCs and building management systems. The MODBUS protocol is also supported through GSM and PSTN modems.

The unit is designed for front panel mounting. Connections are made with 2 part plug and socket connectors.

## MEASUREMENTS

Generator Volts: U-N, V-N, W-N  
 Generator Volts: U-V, V-W, W-U  
 Generator Amps: U, V, W  
 Generator total KW  
 Generator pf  
 Generator Frequency,  
 Engine rpm,  
 Mains Volts: R-N, S-N, T-N  
 Mains Volts: R-S, S-T, T-R  
 Battery Voltage  
 Engine Coolant Temperature  
 Engine Oil Pressure  
 Fuel Level

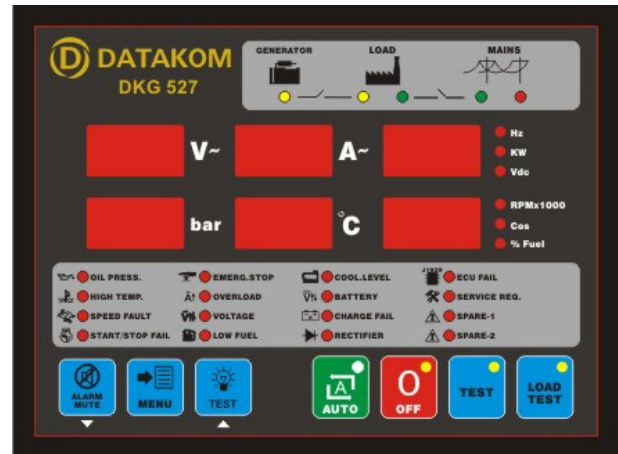

## FEATURES

- Automatic mains failure**
- ECU control and monitoring through J1939 CAN**
- Various engine brands and models available**
- Engine control**
- Generator protection**
- Built in alarms and warnings**
- Remote Start operation available**
- Periodic maintenance request indicator**
- Daily / weekly / monthly exerciser**
- Event logging with time stamp**
- Statistical counters**
- Battery backed-up real time clock**
- Weekly operation schedule programs**
- Provision for dual genset operation**
- Field adjustable parameters**
- RS-232 serial port**
- Free MS-Windows Remote monitoring SW:**
  - local, LAN, IP and modem connection
  - monitoring, download of parameters
  - modem networking
- GSM and PSTN modem support**
- GSM SMS message sending on fault**
- MODBUS communications**
- LED displays**
- Configurable analogue inputs: 2**
- Configurable digital inputs: 8**
- Configurable relay outputs: 2**
- Total relay outputs: 6**
- 30 Amp rated fuel and crank relay outputs**
- I/O expansion capability**
- Survives cranking dropouts**
- Sealed front panel**
- Plug-in connection system for easy replacement**

## STATISTICS

Following incremental counters provide statistics about past performance of the generating set:

- Engine Hours Run
- Engine Hours to Service
- Time to Service
- Number of Engine Cranks
- Number of Genset Runs
- Number of Genset on Load

## EVENT LOGGING

The DKG-527 records last 32 events with date and time stamp. Recorded events are:

- alarms and warnings
- generator on-load/off-load information

## WEEKLY OPERATION SCHEDULE

In AUTO mode only, the unit offers the capability of defining a weekly operation schedule. Programmable parameters allow the genset to operate automatically only in defined time limits of each weekday.

The internal battery backed-up real time clock allows precise switching times.

## DIGITAL INPUTS

The unit has 8 configurable digital inputs. Each input has following programmable parameters:

- alarm type: shutdown / warning / no alarm
- alarm polling: on engine running / always / on mains OK
- latching / non-latching operation,
- contact type: NO / NC
- switching: BAT+ / BAT-

## ANALOG INPUTS

Engine analog inputs are provided for the coolant temperature, oil pressure and fuel level. Analog inputs connect to resistive sender units to provide precise and adjustable protection. The coolant temperature and oil pressure inputs have programmable sensor characteristics so that they are suitable for any type and any brand of sensors.

## RELAY OUTPUTS

The unit provides 6 relay outputs and 2 of them have programmable functions, selectable from a list. Any function or alarm condition may be output as a relay contact.

Using two Relay Expansion Modules, the number of relays may be increased up to 22, 16 of them being volt-free contacts.

## TELEMETRY AND REMOTE PROGRAMMING

The unit provides the user with large telemetry facilities via its standard RS-232 serial port, connecting either to a PC, PLC or a GSM or PSTN modem. It supports both RAINBOW and MODBUS communication protocols. The standard PC software offers local, Local Area Network (LAN), internet and modem operation capabilities as well as modem networking feature.

The PC program is used for below purposes:

- parameter upload/download
- remote monitoring and control
- diagnostics and analysis

The MODBUS interface allows the unit to be integrated in building management systems.

## TECHNICAL SPECIFICATIONS

**Alternator voltage:** 0 to 300 V-AC (Ph-N)

**Alternator frequency:** 0-100 Hz.

**Mains voltage:** 0 to 300 V-AC (Ph-N)

**Mains frequency:** 0-100 Hz.

**DC Supply Range:** 9.0 to 30.0 V-DC

**Cranking dropouts:** survives 0 V for 100ms.

**Typical Standby Current:** 150 mA-DC

**Maximum Operating Current:** 600 mA-DC (Relay outputs open)

**Generator/Mains Contactor Relay Outputs:** 16 A / 250V

**Fuel and Crank relay outputs:** 30A .

**Other DC relay outputs:** 10A @ 28 VDC.

**Charge excitation current:** min 150mA @ 10 to 30 V-DC.

**Current inputs:** from CTs, .../5A. Max load 0.7VA per phase.

**Analog input range:** 0-5000 ohms.

**Serial port:** RS-232, 9600 bauds, no parity, 1 bit stop

**Operating temp.:** -20°C (-4°F) to 70 °C (158°F).

**Storage temp.:** -40°C (-40°F) to 80 °C (176°F).

**Dimensions:** 202 x 148 x 48 mm (WxHxD)

**Panel Cut-out Dimensions:** 183x134 mm minimum.

**Weight:** 460 g (approx.)

**Case Material:** High Temperature ABS (UL94-V0, 100°C)

**IP Protection:** IP65 from front panel, IP30 from the rear.

**Conformity (EU directives)**

-2006/95/EC (low voltage)

-2004/108/EC (electro-magnetic compatibility)

**Norms of reference:**

EN 61010 (safety requirements)

EN 61326 (EMC requirements)

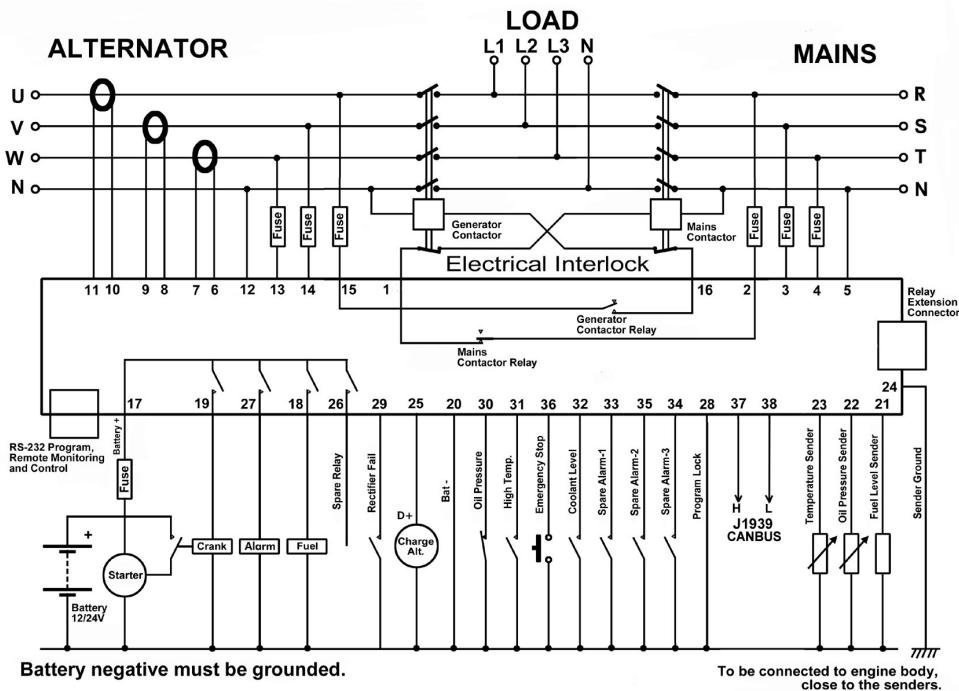

**DATAKOM Electronics Ltd.**

Tel : +90-216-466 84 60

Fax : +90-216-364 65 65

http: [www.datakom.com.tr](http://www.datakom.com.tr)

e-mail : [datakom@datakom.com.tr](mailto:datakom@datakom.com.tr)