

## DKG-114 MANUAL AND REMOTE START UNIT

### APPLICATIONS

- Manual gensets,
- Automatic gensets with voltage relay
- Diesel pumps
- Marine gensets
- Marine auxiliary gensets
- Marine diesel engines

### DESCRIPTION

The DATAKOM model DKG-114 is a low cost, microprocessor controlled generator control unit designed to start and stop the genset both manually and remotely. The manual control is made using the pushbuttons on the front panel. The remote control is made via the remote start input signal.

In the **STOP** position, the DC supply is removed from the module, thus zero power consumption is achieved.

The unit powers up when the **RUN** button is pressed or **battery+** is applied to the **REMOTE START** input. This will also energize the fuel solenoid relay. The engine is automatically started 3 times until operation.

Once the engine is running, the device monitors the internal protections and external fault inputs. Only the first occurring alarm will be displayed, disabling further alarms.

If the **STOP** button is pressed or the **REMOTE START** signal is removed, the engine will be stopped.

The unit offers jumper selectable operating parameters, which lets it to be used in a large variety of applications. The jumper options select the operating voltage of the unit, the auxiliary relay function, the engine running signal type and the cooldown cycle.

The unit fits into a standard 72x72mm panel meter opening and offers a very cost effective and space saving solution for the basic genset control. Thanks to the completely sealed structure, IP65 protection degree is achieved from the front panel.

The unit works on both 12 Volt and 24 Volt gensets.



### FEATURES

- Both manual and remote controlled engine starting and stopping,*
- Automatic shutdown on fault condition,*
- Optional cooldown cycle on remote start operation,*
- Optional energize to stop or preheat output,*
- Survives cranking dropouts,*
- High current relay outputs,*
- Selectable engine running signal (from genset voltage or charge alternator),*
- Delayed overspeed and underspeed alarm,*
- Sealed front panel, IP65 protection.*
- Plug-in connection system for easy replacement,*
- Low cost,*
- Small dimensions,*
- Standard panel dimensions, (72x72mm)*

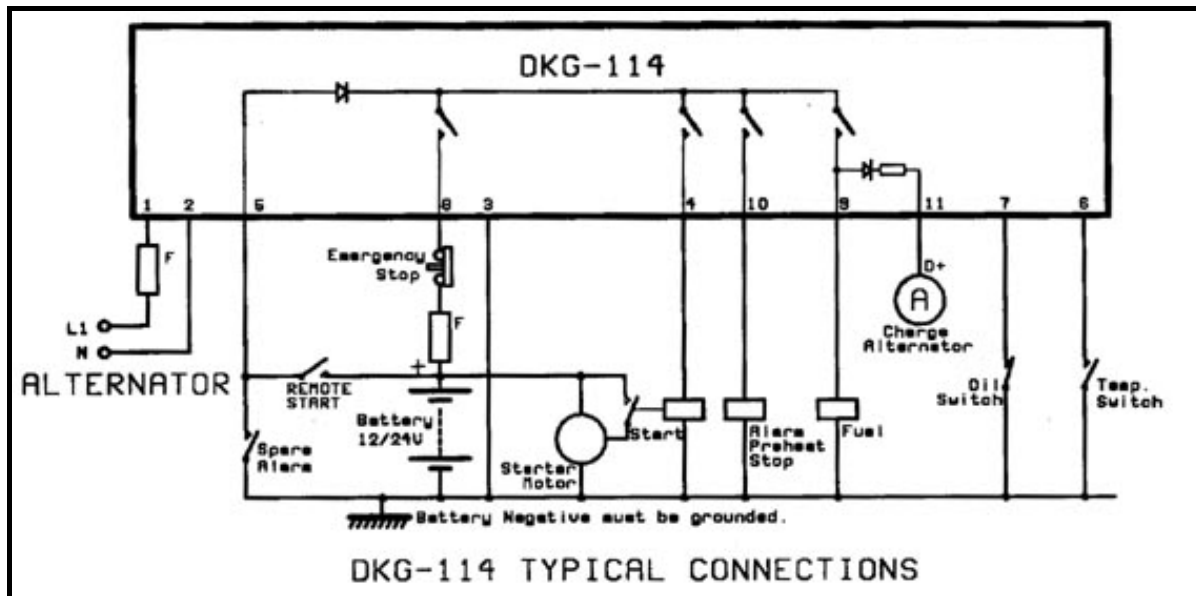

## INPUTS AND OUTPUTS

- FUEL:** Fuel solenoid control. (10 A @28V-DC)
- START:** Engine starter solenoid control. (10 A @28V-DC)
- AUXILIARY:** Positive output relay activated by any alarm condition (or optionally stop solenoid or preheat output). (10 A @28V-DC)
- LOW OIL PRESSURE SWITCH:** negative closing switch input for low oil pressure protection.
- HIGH TEMP SWITCH:** negative closing switch input for engine high temperature protection.
- DC SUPPLY:** 12 or 24 volts DC, (+) and (-) terminals.
- REMOTE START/SPARE FAULT:** If the battery positive voltage is applied to this input the genset will start. If the positive voltage is removed, it will stop. A battery negative connection will generate a SPARE ALARM.
- CHARGE:** This terminal will be connected to the charge alternator D+ terminal. It will supply the excitation current and monitor the charge alternator status.
- G:** Generator phase voltage.
- NEUTRAL:** Generator neutral terminal.

## TECHNICAL SPECIFICATIONS

- Alternator voltage:** 277V-AC (Ph-N)
- Alternator frequency:** 0-200Hz.
- DC Supply Range:** 9 to 33 V-DC.  
4 to 33 V-DC while cranking
- Current consumption:**  
0 ma-DC in OFF mode  
250 mA-DC max. (Relay outputs open)
- Total DC Current Output Rating:** 10A-DC.
- Max. Current for each Terminal:** 10A-RMS.
- Operating temp:** -30°C (-22°F) to 70°C (158°F).
- Storage temp:** -40°C (-40°F) to 80°C (176°F).
- Maximum humidity:** 95% non-condensing.

**IP Protection:** IP65 from front panel, IP30 from the rear.

**Dimensions:** 72 x 72 x 43mm (WxHxD)

**Mounting:** Front panel mounted with rear retaining steel spring.

**Panel cut-out dimensions:** 68 x 68mm.

**Weight:** 180 g (approx.)

**Charge excitation current:** 36mA @ 12V-DC.

**Cranking dropouts:** survives 0V for 100ms.

**Genset low frequency limit:** 30Hz.

**Genset high frequency limit:** 57Hz.

**Frequency error delay:** 3 sec.

**Preheat timer:** 10 or 30 sec selectable.

**Number of starts:** 3

**Start duration:** 6 sec.

**Wait between starts:** 10 sec.

**Cooldown duration:** 2 min.

**Stop duration:** 30 sec.

**Alarm duration:** 1 minute.

**Protection delay:** 10 sec.

**Case Material:** Flame Retardant High Temperature ABS (UL94-V0, 110°C)

**Conformity (EU directives)**

-73/23/EEC and 93/68/EEC

-89/336/EEC, 92/31/EEC and 93/68/EEC

**Norms of reference:**

EN 61010 (safety requirements)

EN 50081-2 (EMC requirements)

EN 50082-2 (EMC requirements)

Tel : +7 (8617) 70-96-41

Fax : +7 (8617) 61-23-66

e-mail : datakom@datakom.com.ru

http: www.datakom.com.ru