

DKG-152 REMOTE START UNIT

DESCRIPTION

The DATAKOM model DKG-152 is a low cost, microprocessor controlled unit designed to start and stop the genset automatically on request of an external Remote Start signal. It has **high power relay outputs** enabling it to interface directly with diesel gensets.

When the engine is running, the unit monitors fault conditions and shuts-down the engine automatically in the occurrence of an alarm. The alarms are identified by a group of LEDs displaying only the first occurring one.

The DKG-152 is also able to control 'Energize to Stop' type of engines. The engine type selection is made by a jumper switch.

In the **OFF** position, the DC supply is removed from the module, thus remote start operation is disabled and zero power consumption is achieved.

The unit powers up when the **AUTO** position on the front panel is selected. It will start the engine when its Remote Start input is pulled to battery negative.

When the Remote Start signal arrives, the unit will act like below:

If 'Preheat' option is selected, it energizes the **AUXILIARY** relay output for **Preheat Delay**, then releases it.

Then it energizes the **FUEL** relay output for **Wait Before Start** delay, then energizes the **START** relay output for **Start Duration**. If the engine fires, the start relay is immediately released. The protections will be enabled only after the **Protection Hold-off Timer** has expired.

If the engine does not fire, start and fuel outputs are deenergized and the unit will wait for **Wait Between Starts** period.

If 'preheat' option is selected, the **AUXILIARY** relay output will be energized during this period.

Then a new crank cycle is initiated. The engine is cranked up to 3 times.

When the Remote Start signal disappears, the engine will continue to run for **Cooldown Duration**. Then the fuel relay is deenergized.



If the 'Activate to Stop' option is selected, the **AUXILIARY** relay output will be energized for **Stop Timer**. At the end of the stop cycle the unit will be ready for a new Remote Start cycle.

The **PREHEAT/STOP** (⚙️) led will continuously indicate the **AUXILIARY** relay status.

The occurrence of below fault conditions will cause the engine to be stopped immediately:

- Overspeed,
- Underspeed,
- High engine temperature,
- Low oil pressure,

If a fault condition occurs, the **FUEL** solenoid will be deenergized. If the 'Energize to Stop' option is selected, the **AUXILIARY** relay output will be energized during **Stop Timer** and the led associated with this condition will turn on.

Only the first occurring fault will be indicated. To reset the fault condition, turn the switch to the **OFF** position for a few seconds.

The **Charge Fail** condition is treated as a warning only and do not cause the engine to stop. The input monitors the **D+** terminal of the charge alternator.

The unit is able to operate in both 50 and 60 Hz systems. The selection is made with a jumper switch.

The unit uses high current two part connectors for easy replacement.

TYPICAL CONNECTION DIAGRAM

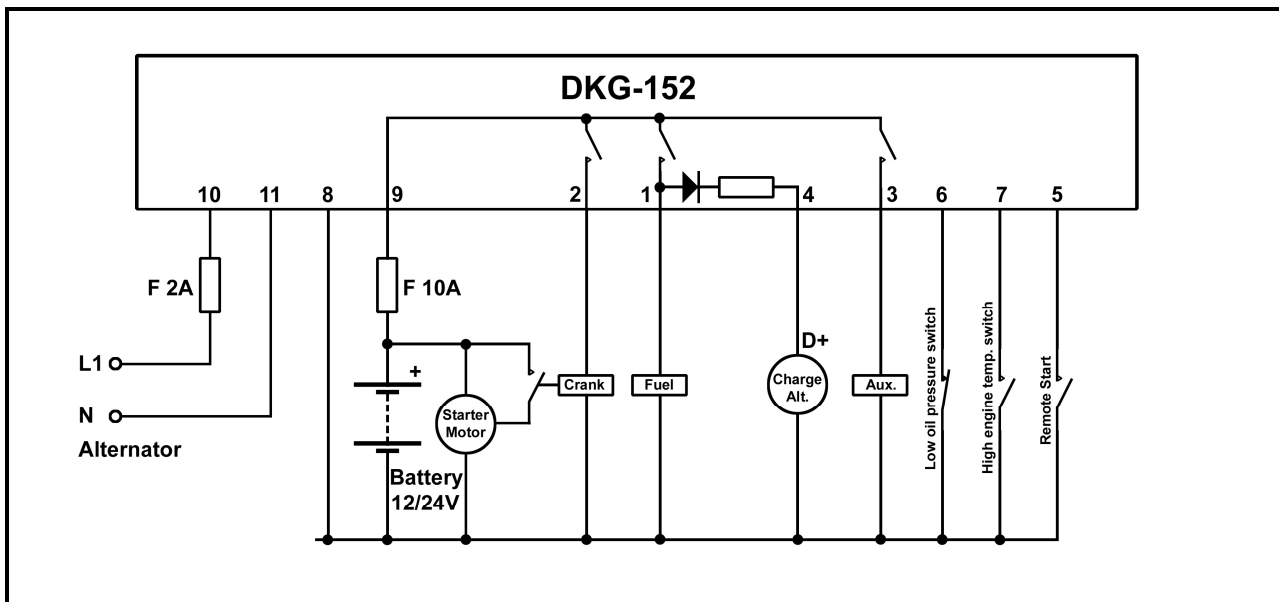

INPUTS

DC SUPPLY: 12 or 24 volts DC, (+) and (-) terminals.

L1: Generator phase voltage.

NEUTRAL: Generator neutral terminal.

HIGH TEMP SWITCH: Negative closing switch input.

LOW OIL PRESSURE: Negative closing switch input.

REMOTE START: A negative supply connection to this input will cause the engine to run.

CHARGE: Connect the charge alternator's D+ end to this terminal. This terminal will supply the excitation current and measure the voltage of the charge alternator.

OUTPUTS

FUEL SOLENOID : 10amps@28V-DC.

START : 10amps@28V-DC.

AUXILIARY : 10amps@28V-DC.

OPTIONS

JUMPER SELECTABLE STANDARD FEATURES:

Preheat with Activate to Start,
Energize to Stop without preheat,
50Hz nominal,
60Hz nominal.

OPTIONAL FEATURES: (SUBJECT TO SPECIAL ORDER)

Engine control (without alternator),
Manual Start version (DKG-151)
Negative pulling semiconductor outputs (DKG-154).
Different timer values.

TECHNICAL SPECIFICATIONS

Alternator Voltage: 15 to 300 V-AC

Alternator Frequency: 50 or 60 Hz nominal.

Overspeed: nominal frequency + 14%
(+ 24% overshoot)

Underspeed: 25Hz

DC Supply Range: 8 to 33 V-DC.

Current consumption: 80mA max. (Outputs open).

Charge fail threshold: 6 V-DC.

Charge excitation current: via 82 ohms resistor
connected to the FUEL output.

Preheat Delay: 10 sec.

Wait Before Start: 0.75 sec.

Start Duration: 6 sec.

Wait Between Starts: 10 sec.

Number of Start Cycles: 3

Protection Hold-off Timer: 12 sec.

Cooldown Duration: 2 minutes.

Stop Timer: 30 sec.

Operating temp.: -20°C (-4°F) to 70 °C (158°F).

Storage temp.: -30°C (-22°F) to 80 °C (176°F).

Maximum humidity: 95% non-condensing.

Dimensions: 72x72x38mm (WxHxD)

Panel cutout dimensions: 68x68 mm

Weight: 140g (approx.)

Installation: Front panel mounted. Retaining steel
spring provided.

Tel : +7 (8617) 70-96-41

Fax : +7 (8617) 61-23-66

e-mail : datakom@datakom.com.ru

http: www.datakom.com.ru